

ITB# 2401710140001

City of Hendersonville
Addendum

ADDENDUM 3

Date of Addendum: March 13, 2025

Project Name: COH Ops Building Renovation

The attention of all Bidders on the above Contract is called to this Addendum No. 3:

A. REVISIONS TO DRAWING SHEETS

- a. Delete sheets A101 and A102 from the architectural drawings and replace with the attached Sheets A101 and A102.
 - i. Scope increase: include ELEC 156 in renovation scope
 - ii. Scope increase: clean tile and grout at ENTRY 100
 - iii. Scope Change: walls at ASSEMBLY 104 are 2hr fire rated
 - iv. See note 8 on FLOOR PLAN NOTES BY NUMBER for renovation instructions.

B. REVISIONS TO THE PROJECT MANUAL

- a. Add the attached items to the project manual
 - i. Bid Bond Form
 - ii. Performance Bond Form
 - iii. Payment Bond Form
- b. Include the bid bond with your bid

C. ANSWERS TO QUESTIONS

- a. *Will the Client provided storage (AD-101 Note 10) be onsite or will it require transportation?*
 - i. The footprint of the workspace can be used for furniture storage during construction. Day Room 157 could be a good option for office furniture storage. Assembly 104 could be worked in phases moving odd shaped items, such as the curved city council dais, from one side of the room to the other.
 - ii. If needed, the recently acquired building at 110 Williams St, directly next door to the City Operations Building, could be used for storage. The approximately 4,000 sf space has recently been cleared out and demolished down the studs.
 - iii. City staff will continue to move personal items out of the workspace but will not be moving furniture or large items.
- b. *Have the plans already been submitted to the inspection department for pre-approval?*
 - i. The plans have not been submitted for pre-approval.

CITY OF HENDERSONVILLE



Richard Shook, PE
Civil Engineer



City of Hendersonville



14 OHENRY AVENUE, SUITE 210 ASHEVILLE, NC 28801 TEL. 828.254.1963 WWW.LS3P.COM

COPYRIGHT 2024 ALL RIGHTS RESERVED. PRINTED OR ELECTRONIC DRAWINGS AND DOCUMENTATION MAY NOT BE REPRODUCED IN ANY FORM WITHOUT WRITTEN PERMISSION FROM LS3P ASSOCIATES LTD.

COH-Ops Building Finishes Renovations 305 Williams St Hendersonville, North Carolina 28792 LS3P PROJECT: 0101-240874

Table with 2 columns: DATE, DESCRIPTION. Row 0: 2025.03.12, ADDENDUM 2

SHEET NAME: BASE BID - FLOOR PLAN- LEVEL 1

ORIG SUBMISSION: 2025.01.10

SHEET: A-101

ROOM FINISHES - BASE BID table with columns: NUMBER, NAME, WALL, FINISH, FLOOR, NOTES. Lists rooms 100-159 and their respective finishes.

FLOOR PLAN NOTES BY NUMBER table with columns: NUMBER, NOTE. Lists notes 1-8 regarding floor finishes and electrical needs.

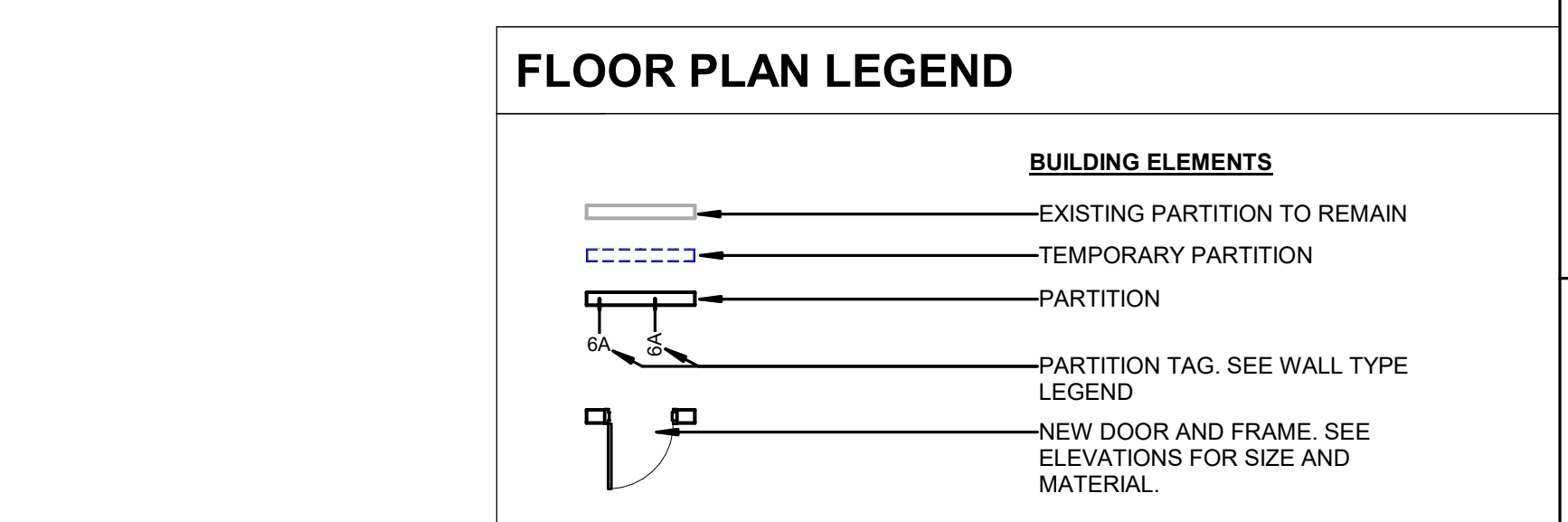
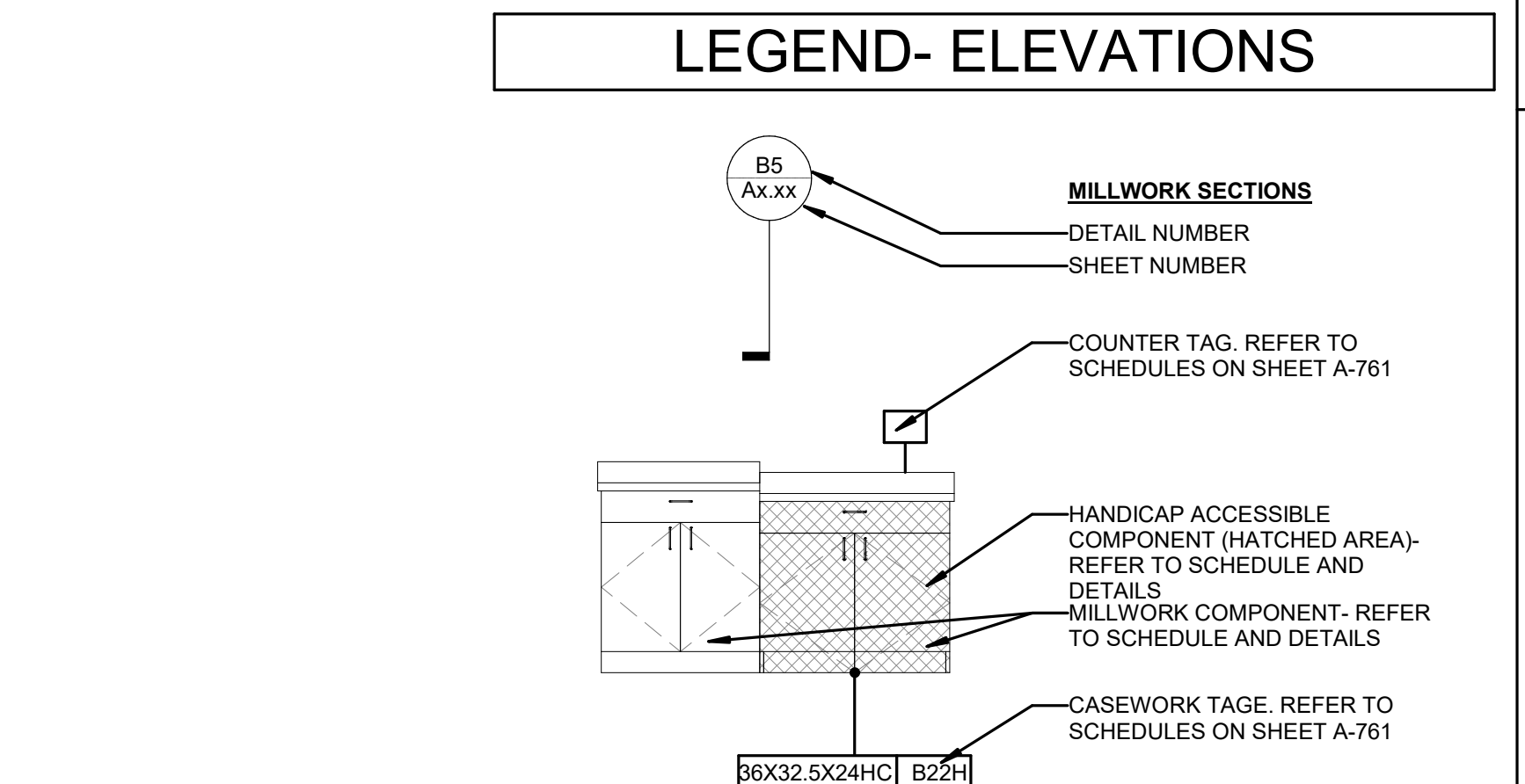

FLOOR PLAN SHEET NOTES A-H: A. PATCH AND REPAIR ALL DRYWALL MISSING AT BASE OF WALLS... B. CALCULATE ALL MILLWORK... C. INTERIOR DIMENSIONS INDICATED ARE TO FACE OF STUD... D. LOCATE DOOR OPENINGS 4" FROM NEAREST PERPENDICULAR WALL... E. WHERE PARTITIONS OF DIFFERENT FIRE RATINGS INTERSECT... F. INSTALL BLOCKING IN PARTITIONS FOR CASEWORK... G. FIELD VERIFY LOCATION OF INTERIOR WALL & CEILING CONTROL JOINTS... H. WALLS, INCLUDING GYP. BD. AT PERIMETER OF ROOMS/SPACES WITHOUT CEILINGS...

FLOOR FINISH LEGEND

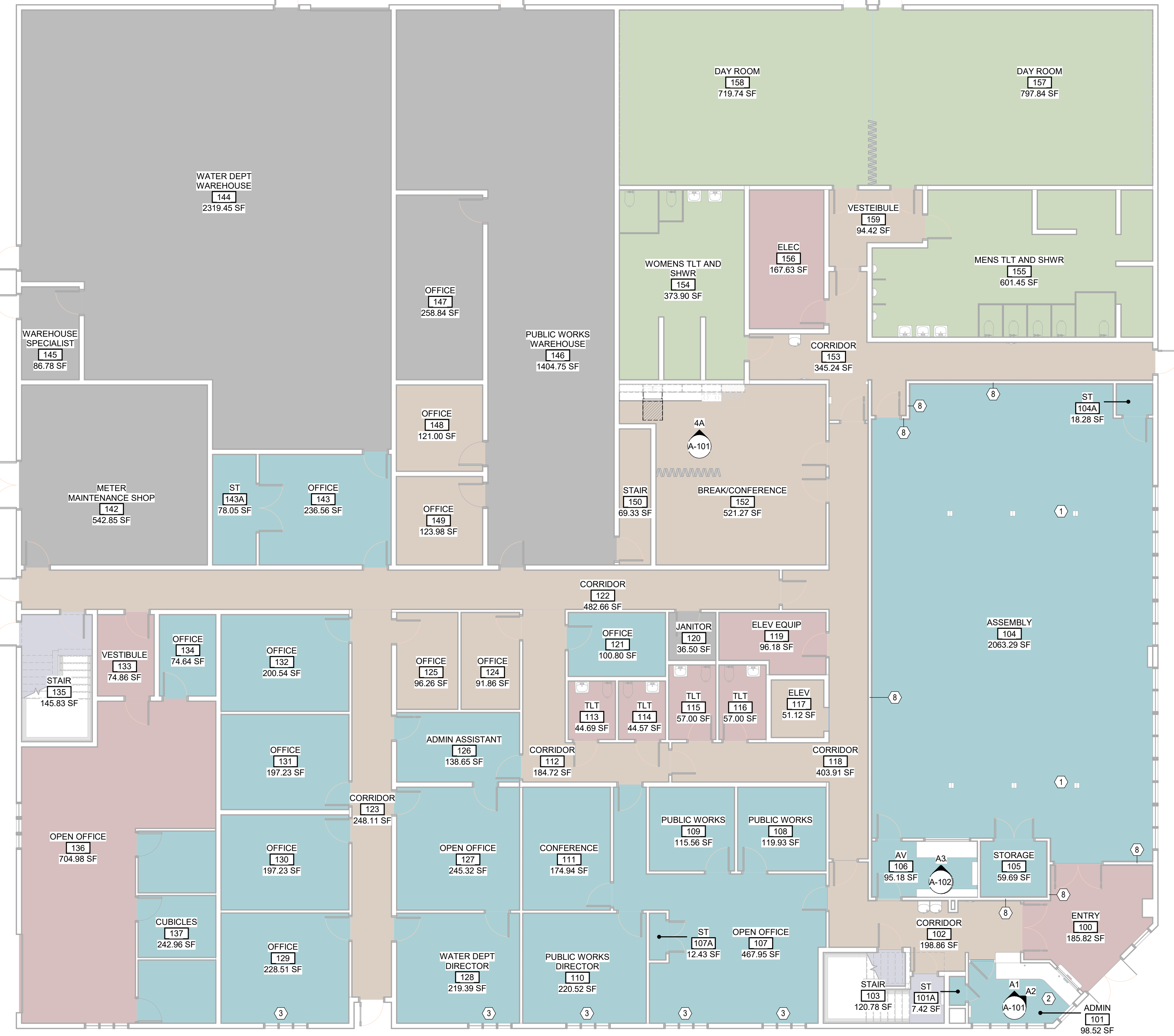

B1 BASE BID FLOOR PLAN 1/8" = 1'-0"

A1 ELEV - ADMIN 101 N 3/8" = 1'-0"

A2 ELEV - ADMIN 101 NE 3/8" = 1'-0"

3A ELEV - AV 106 N 3/8" = 1'-0"

4A ELEV - BREAK 152 N 3/8" = 1'-0"

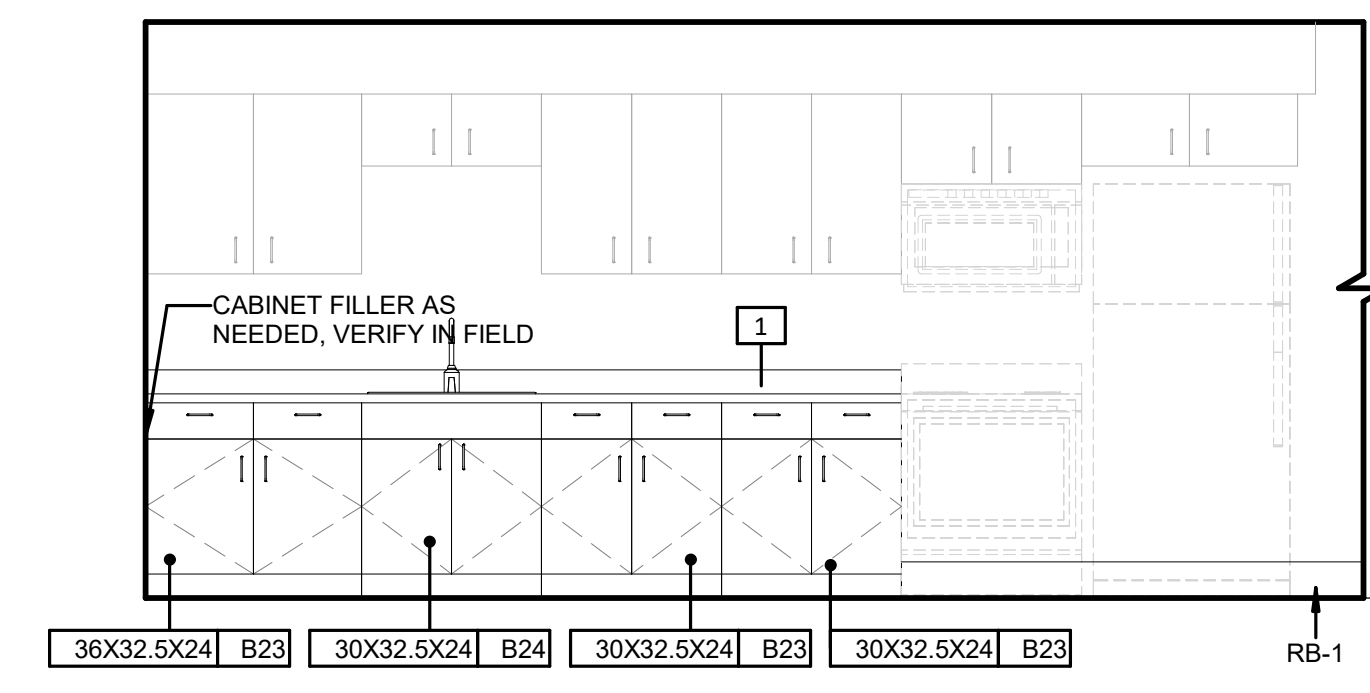
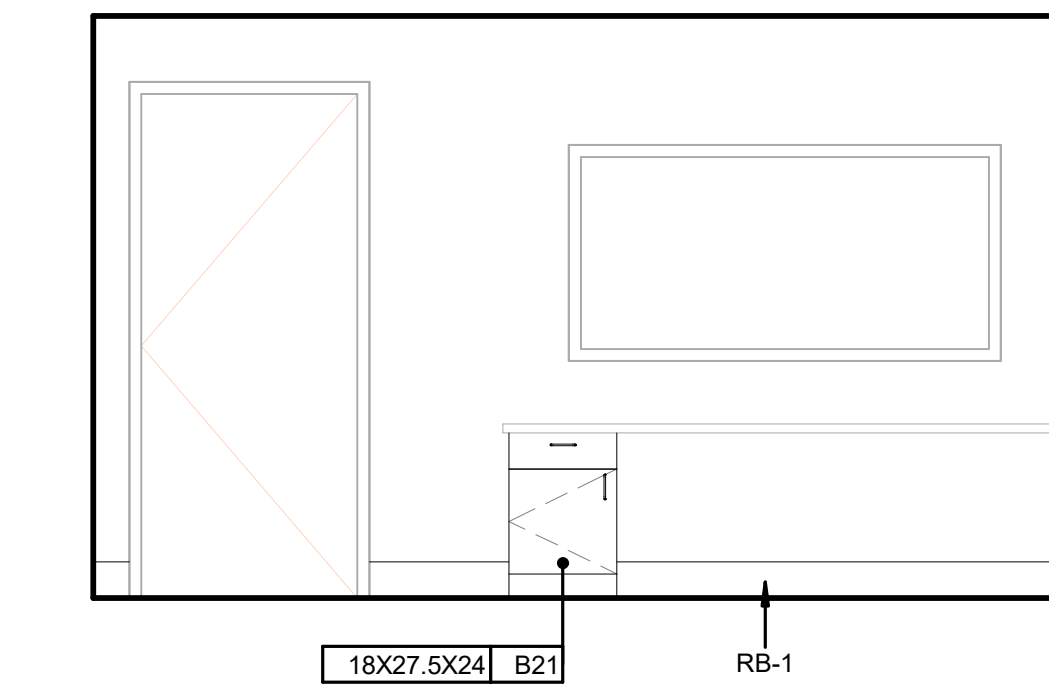
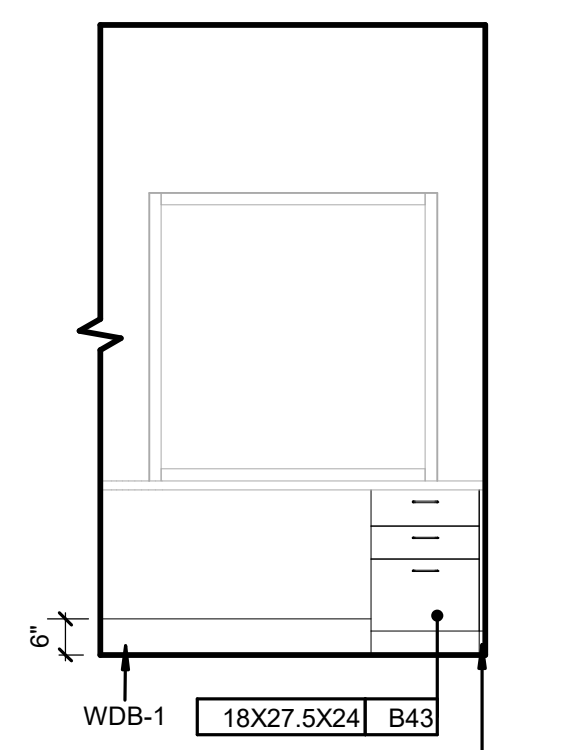
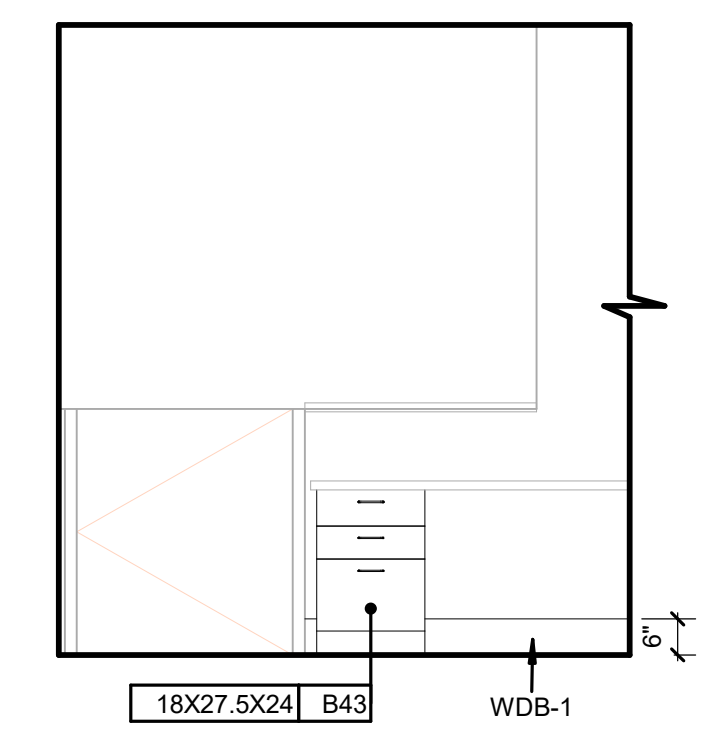

Vertical grid lines A through E and horizontal grid lines 1 through 6.

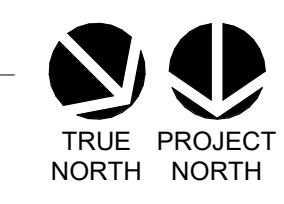

3/11/2025 4:19:56 PM



City of Hendersonville



14 O'HEEN AVENUE, SUITE 210 ASHEVILLE, NC 28801 TEL. 828.254.1963 WWW.LS3P.COM

COPYRIGHT 2024 ALL RIGHTS RESERVED. PRINTED OR ELECTRONIC DRAWINGS AND DOCUMENTATION MAY NOT BE REPRODUCED IN ANY FORM WITHOUT THE WRITTEN PERMISSION FROM LS3P ASSOCIATES LTD.

COH-Ops Building Finishes Renovations 305 Williams St Hendersonville, North Carolina 28792 LS3P PROJECT: 0101-240874

Table with columns: DATE, DESCRIPTION, 0 2025.03.12, ADDENDUM 2

SHEET NAME: ALTERNATE 1 - FLOOR PLAN - LEVEL 1

ORIG SUBMISSION: 2025.01.10

SHEET: A-102

ROOM FINISHES - ALTERNATE

Table with columns: NUMBER, NAME, WALL, FINISH, BASE, FLOOR, NOTES. Lists room finishes for various rooms like ENTRY, CORRIDOR, OFFICE, etc.

FLOOR PLAN NOTES BY NUMBER. List of notes for rooms 1 through 8.

LEGEND - ELEVATIONS

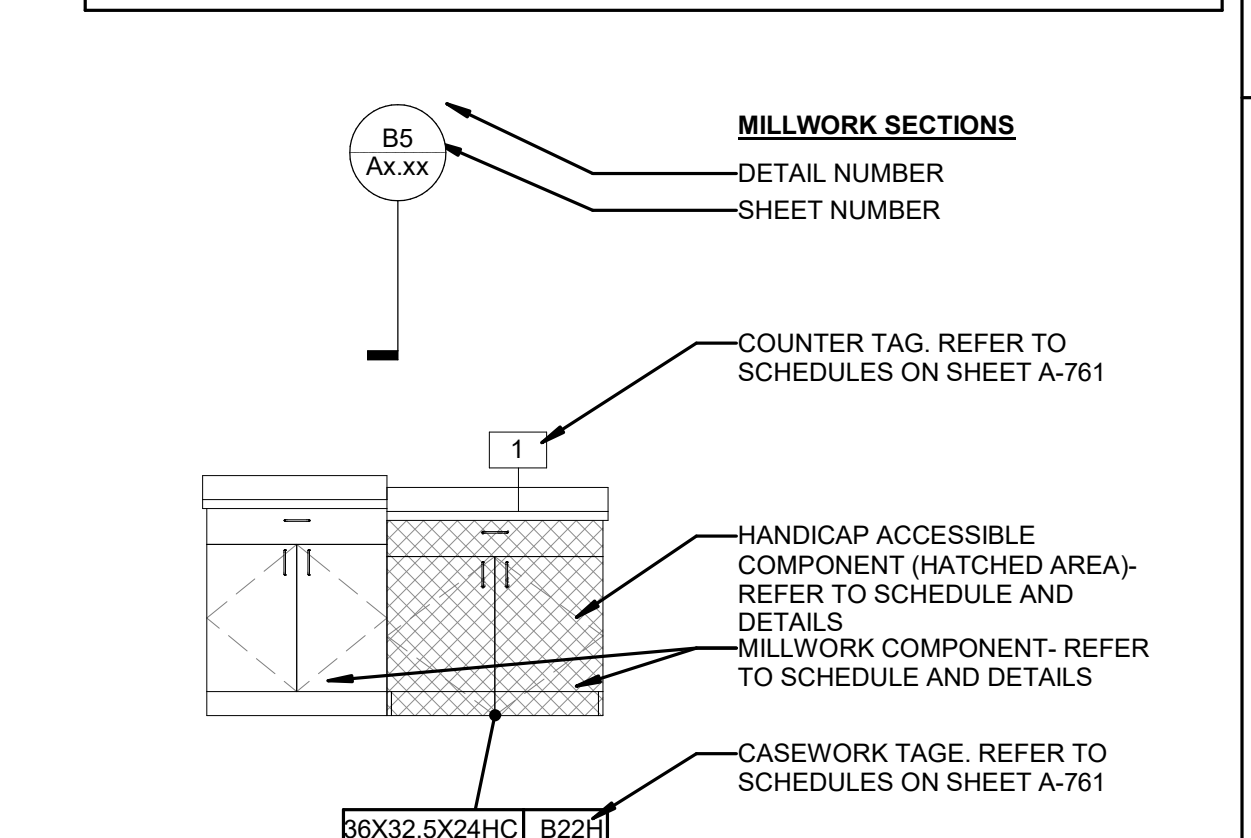

FLOOR PLAN LEGEND

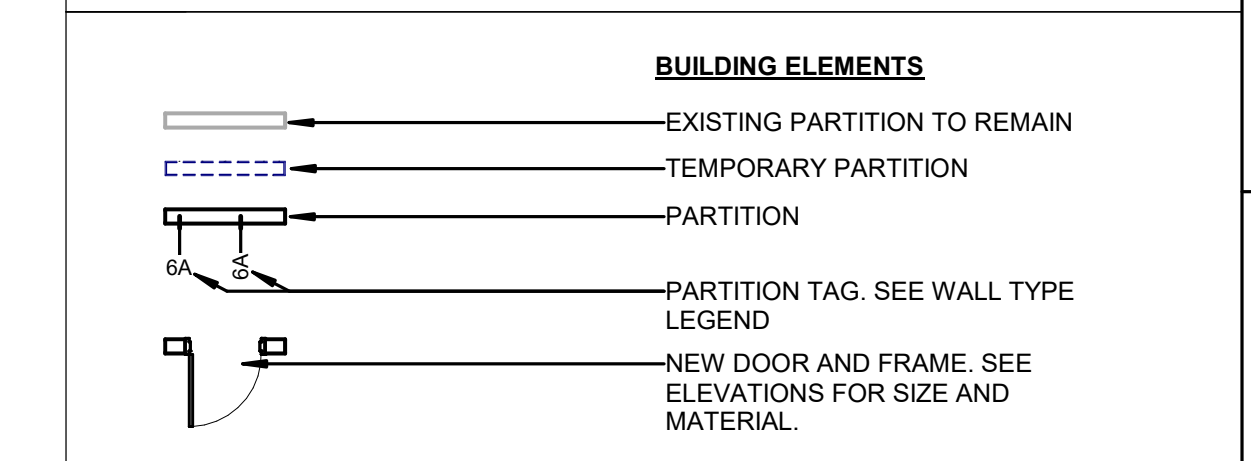

FLOOR PLAN SHEET NOTES

- A. PATCH AND REPAIR ALL DRYWALL MISSING AT BASE OF WALLS. PAINT NEW GWB TO MATCH ADJACENT EXISTING WALL. ALL NEW BASE TO BE RB-1 UNLESS OTHERWISE SPECIFIED.
B. CALK ALL LOW MILLWORK (CASEWORK, WALL BASE, COUNTERS, ETC.) SEAMS AT WALL.
C. INTERIOR DIMENSIONS INDICATED ARE TO FACE OF STUD, FACE OF MASONRY AND CENTERLINES OF COLUMNS, LINO.
D. LOCATE DOOR OPENINGS 4" FROM NEAREST PERPENDICULAR WALL.
E. WHERE PARTITIONS OF DIFFERENT FIRE RATINGS INTERSECT, THE HIGHEST RATED PARTITION SHALL CONTINUE THROUGH MAINTAIN PARTITION FIRE RATING BEHIND RECESSED FIRE EXTINGUISHER CABINETS.
F. INSTALL BLOCKING IN PARTITIONS FOR CASEWORK, WALL MOUNTED EQUIPMENT, TRIM, AND RELATED CONSTRUCTION.
G. FIELD VERIFY LOCATION OF INTERIOR WALL & CEILING CONTROL JOINTS REQUIRED IN THE SPECIFICATION WITH ARCHITECT PRIOR TO INSTALLATION.
H. WALLS, INCLUDING GYP. BD. AT PERIMETER OF ROOMS/SPACES WITHOUT CEILINGS, I.E. EXPOSED STRUCTURE, SHALL EXTEND TO STRUCTURE ABOVE.

FLOOR FINISH LEGEND

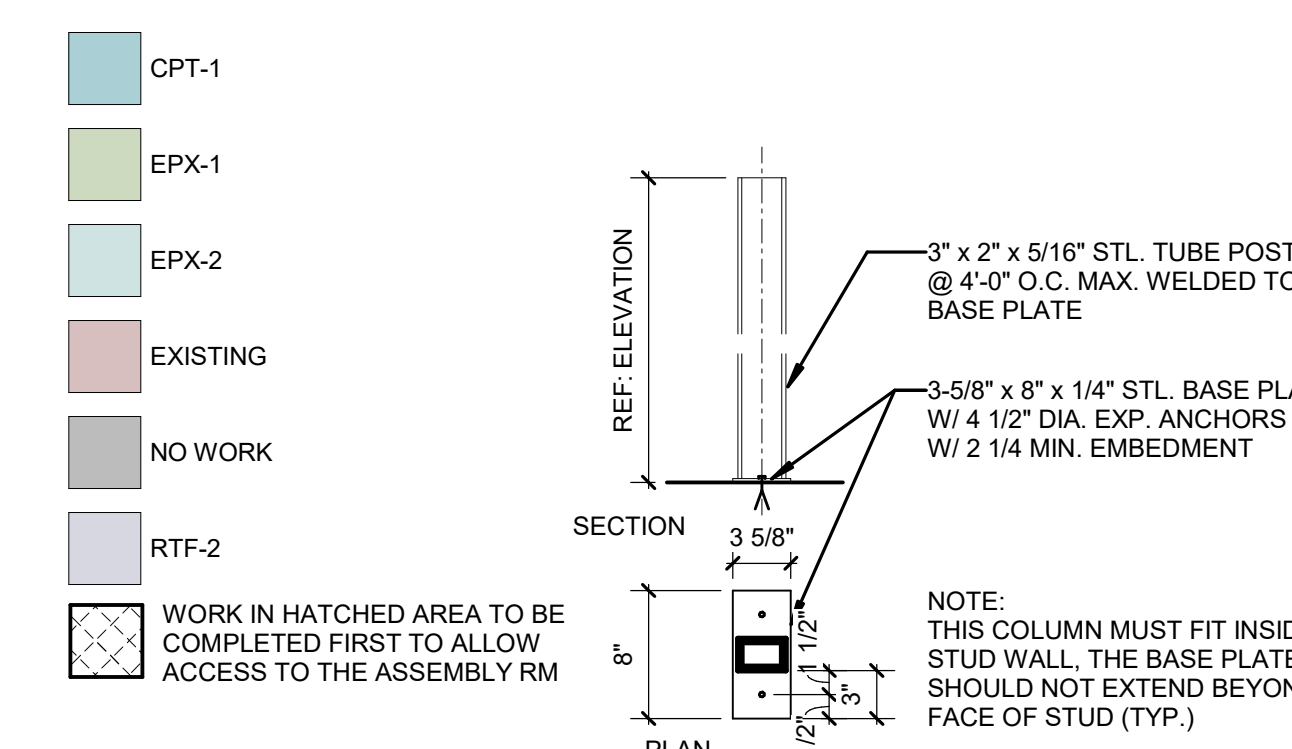

(PARTITION - FREE STANDING SUPPORT)

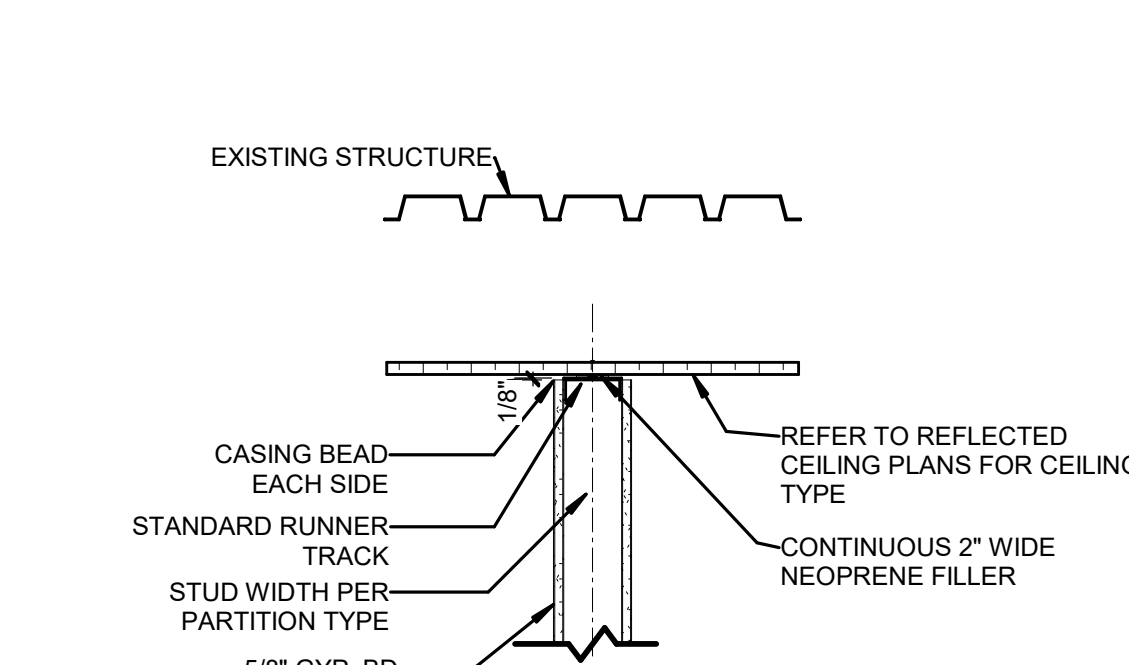

(PARTITION TERMINATED @ CEILING)

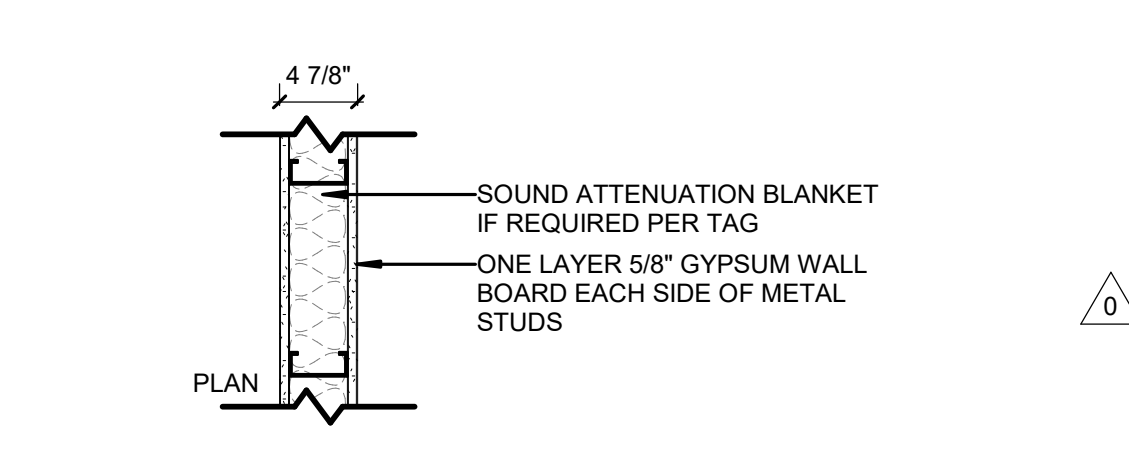

NEW PARTITION DETAILS

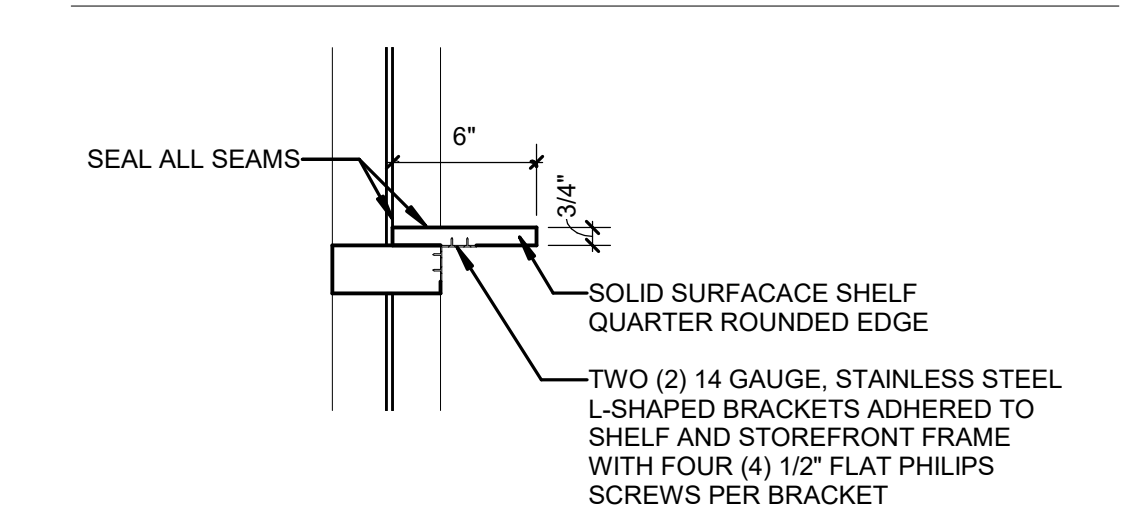

D5 SS-1 SHELF DETAIL

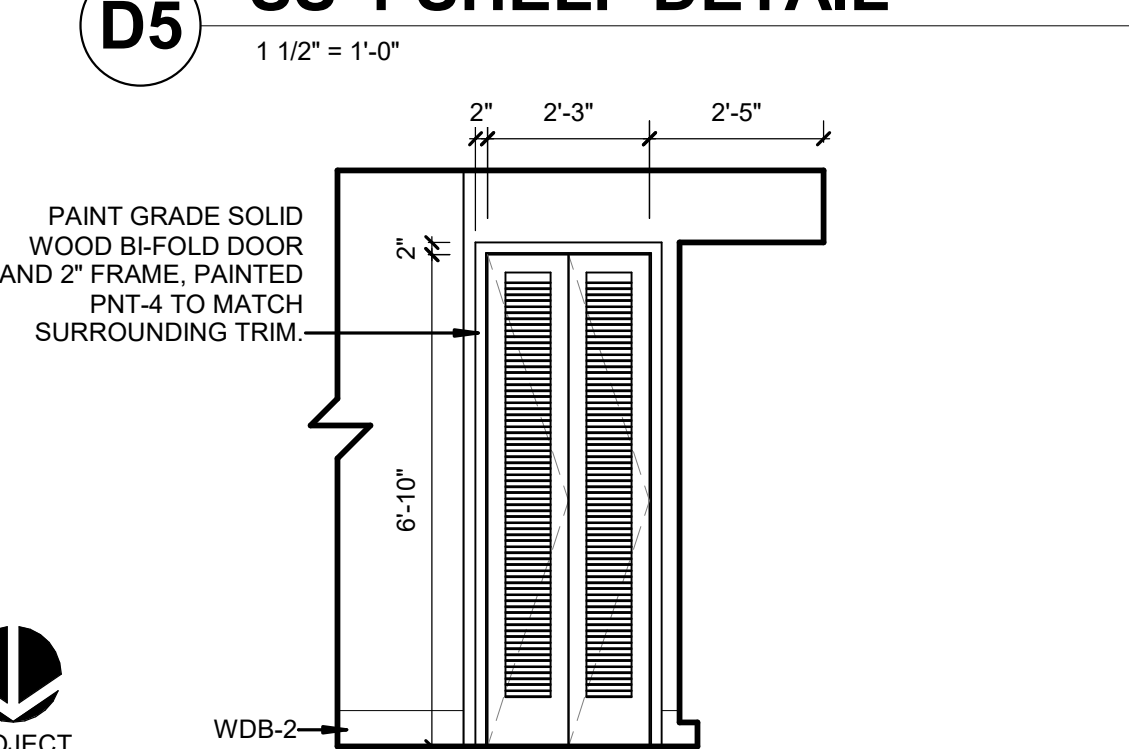

C5 ELEV - BREAK 152 W ALT

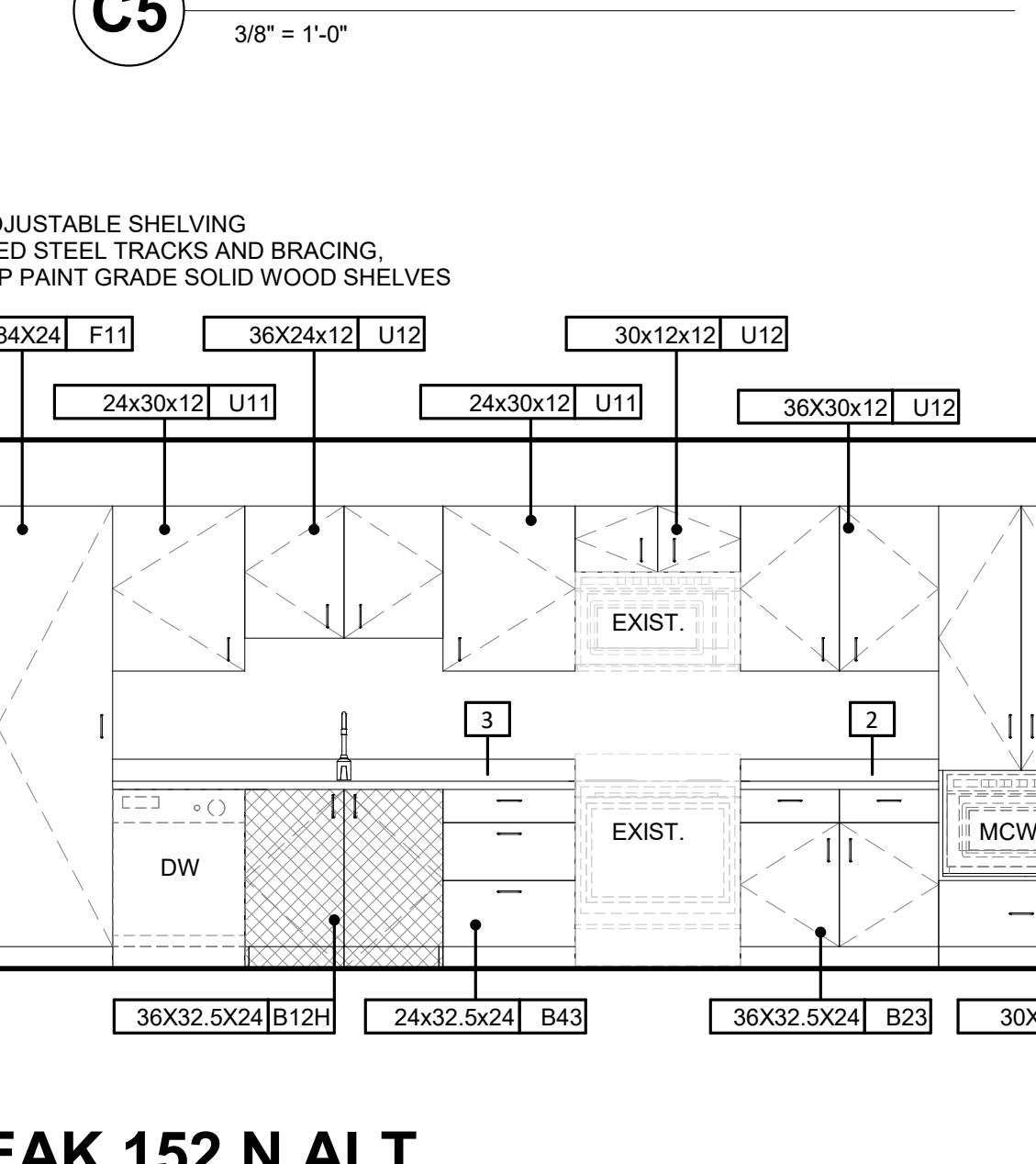

WALL TYPE LEGEND

- 6D 6" METAL STUD, 1 LAYER 5/8" GWB EACH SIDE, SOUND ATTENUATION BLANKET INSULATION, NOT RATED.
3A 3 5/8" METAL STUD, 1 LAYER 5/8" GWB EACH SIDE, NOT RATED.

B1 ALTERNATE FLOOR PLAN

A1 ELEV - CORRIDOR 102 S ALT



A2 ELEV - ADMIN 101 NE ALT



A3 ELEV - AV 106 N ALT

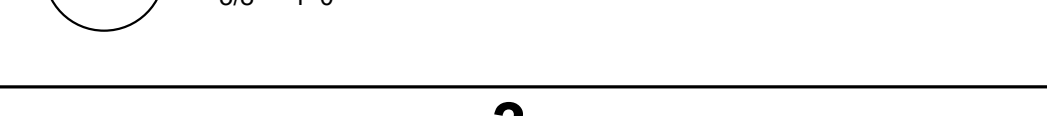

A4 ELEV - BREAK 152 N ALT



FORM OF BID BOND

KNOW ALL MEN BY THESE PRESENTS THAT _____

_____ as principal, and _____, as surety, who is duly licensed to act as surety in North Carolina, are held and firmly bound unto the State of North Carolina* through _____ as obligee, in the penal sum of _____ DOLLARS, lawful money of the United States of America, for the payment of which, well and truly to be made, we bind ourselves, our heirs, executors, administrators, successors and assigns, jointly and severally, firmly by these presents.

Signed, sealed and dated this ____ day of ____ 20__

WHEREAS, the said principal is herewith submitting proposal for and the principal desires to file this bid bond in lieu of making the cash deposit as required by G.S. 143-129.

NOW, THEREFORE, THE CONDITION OF THE ABOVE OBLIGATION is such, that if the principal shall be awarded the contract for which the bid is submitted and shall execute the contract and give bond for the faithful performance thereof within ten days after the award of same to the principal, then this obligation shall be null and void; but if the principal fails to so execute such contract and give performance bond as required by G.S. 143-129, the surety shall, upon demand, forthwith pay to the obligee the amount set forth in the first paragraph hereof. Provided further, that the bid may be withdrawn as provided by G.S. 143-129.1

_____(SEAL)

_____(SEAL)

_____(SEAL)

_____(SEAL)

_____(SEAL)

FORM OF PERFORMANCE BOND

Date of Contract: _____

Date of Execution: _____

Name of Principal
(Contractor) _____

Name of Surety: _____

Name of Contracting
Body: _____

Amount of Bond: _____

Project: City Operation Finishes Renovation

KNOW ALL MEN BY THESE PRESENTS, that we, the principal and surety above named, are held and firmly bound unto the above named contracting body, hereinafter called the contracting body, in the penal sum of the amount stated above for the payment of which sum well and truly to be made, we bind, ourselves, our heirs, executors, administrators, and successors, jointly and severally, firmly by these presents.

THE CONDITION OF THIS OBLIGATION IS SUCH, that whereas the principal entered into a certain contract with the contracting body, identified as shown above and hereto attached:

NOW, THEREFORE, if the principal shall well and truly perform and fulfill all the undertakings, covenants, terms, conditions and agreements of said contract during the original term of said contract and any extensions thereof that may be granted by the contracting body, and including the Correction Period provided in Paragraph 15.08 of the General Conditions of the Contract, with or without notice to the surety, and during the life of any guaranty required under the contract, and shall also well and truly perform and fulfill all the undertakings, covenants, terms, conditions and agreements of any and all duly authorized modifications of said contract that may hereafter be made, notice of which modifications to the surety being hereby waived, then, this obligation to be void; otherwise to remain in full force and virtue.

IN WITNESS WHEREOF, the above-bounden parties have executed this instrument under their several seals on the date indicated above, the name and corporate seal of each corporate party being hereto affixed and these presents duly signed by its undersigned representative, pursuant to authority of its governing body.

Executed in _____ counterparts.

Witness:

(Proprietorship or Partnership)

Attest: (Corporation)

By: _____

Title: _____
(Corp. Sec. or Asst. Sec. only)

(Corporate Seal)

Contractor: (Trade or Corporate Name)

By: _____

Title: _____
(Owner, Partner, or Corp. Pres. or Vice Pres. only)

(Surety Company)

By: _____

Title: _____
(Attorney in Fact)

Witness:

Countersigned:

(N.C. Licensed Resident Agent)

Name and Address-Surety Agency

Surety Company Name and N.C.
Regional or Branch Office Address

(Surety Corporate Seal)

FORM OF PAYMENT BOND

Date of Contract: _____
Date of Execution: _____
Name of Principal
(Contractor) _____
Name of Surety: _____
Name of Contracting
Body: _____
Amount of Bond: _____
Project City Operations Finishes Renovation

KNOW ALL MEN BY THESE PRESENTS, that we, the principal and surety above named, are held and firmly bound unto the above named contracting body, hereinafter called the contracting body, in the penal sum of the amount stated above for the payment of which sum well and truly to be made, we bind ourselves, our heirs, executors, administrators, and successors, jointly and severally, firmly by these presents.

THE CONDITION OF THIS OBLIGATION IS SUCH, that whereas the principal entered into a certain contract with the contracting body identified as shown above and hereto attached:

NOW, THEREFORE, if the principal shall promptly make payment to all persons supplying labor/material in the prosecution of the work provided for in said contract, and any and all duly authorized modifications of said contract that may hereafter be made, notice of which modifications to the surety being hereby waived, then this obligation to be void; otherwise to remain in full force and virtue.

IN WITNESS WHEREOF, the above-bounden parties have executed this instrument under their several seals on the date indicated above, the name and corporate seal of each corporate party being hereto affixed and these presents duly signed by its undersigned representative, pursuant to authority of its governing body.

Executed in _____ counterparts.

Witness:

(Proprietorship or Partnership)

Attest: (Corporation)

Pres. only)

By: _____

Title: _____
(Corp. Sec. or Asst. Sec.. only)

(Corporate Seal)

Contractor: (Trade or Corporate Name)

By: _____

Title _____
(Owner, Partner, or Corp. Pres. or Vice

Witness:

(Surety Company)

By: _____

Title: _____
(Attorney in Fact)

Countersigned:

(Surety Corporate Seal)

(N.C. Licensed Resident Agent)

Name and Address-Surety Agency

Surety Company Name and N.C.
Regional or Branch Office Address